



**ITI LIMITED**  
A Govt. Of India Undertaking  
Dooravaninagar Bangalore  
560016 GSTIN.: 29AAAC14625C1ZV

Phone No 080-25651260/28503947  
Fax 080-25651519/1724/0361  
Email1: cmmx\_bgp@itilttd.co.in  
Email2 rvijayalakshmi\_bgp@itilttd.co.in  
Website: www.itilttd-india.com

Due Date 23-07-2021 15:00

ENQUIRY FOR PR M2121G001

Date 07-07-2021 13:38

**Respected Sir** Kindly quote your best prices and deliveries for the below mentioned components.

Sino	Item and Description	Quantity	Unit
1	ASCRNT-1 "M10 Nutsert (Blind Rivet nut)-Semi-Hex shank , Large Flange , open ( )	2430.0000	Number of Units
2	ASCRVTBLB/1 "Semistructural Dome head Blind Bulb Rivet , Steel-Znplated-Steel-Z ( )	105460.0000	Number of Units
3	ASCRVTBLB/3 "Semistructural Dome head Blind Bulb Rivet , Steel-Znplated-Steel-Z ( )	24300.0000	Number of Units

**NOTE :**

1. PLEASE SEND YOUR QUOTE IN A SEALED COVER SUBSCRIBING OUR ENQUIRY NUMBER AND THE DUE DATE ON THE ENVELOPE SHOULD REACH US ON OR BEFORE DUE DATE BY 3.00 PM.
2. OFFER THROUGH EMAIL WILL NOT BE CONSIDERED.
3. TERMS AND CONDITIONS AS PER ENCLOSURE.
4. OUR PAYMENT IS 60 DAYS CREDIT.
5. YOUR QUOTED PRICE SHALL BE ALL INCLUSIVE FOR ITI LTD.BANGALORE

**Special Note:** \* KINDLY PROVIDE UDYAM REGISTRATION CERTIFICATE IF MSME REGISTERED ENTERPRISE

\* KINDLY MENTION SUBJECT AS "QUOTATION FOR RIVET / NUTSERT"; RFQ # AS "M2121G001" & DUE DATE AS "23.07.2021" OVER ENVELOPE WITHOUT WHICH QUOTATION WILL NOT BE CONSIDERED FOR TENDERING

\* KINDLY ACKNOWLEDGE THE RECEIPT OF ENQUIRY BY RETURN MAIL

\* KINDLY CONFIRM WHETHER QUOTATION SUBMITTED BY PERSONAL DEPOSIT OR THROUGH ANY COURIER SERVICES (PROVIDE DOCKET REFERENCE)

\* KINDLY PROVIDE DATASHEET / TECHNICAL COMPLIANCE / SPECIFICATION DOCUMENT ALONG WITH QUOTATION

\* KINDLY SUBMIT SAMPLES ALONG WITH QUOTATION IF POSSIBLE

\* KINDLY SUBMIT QUOTATION AS PER ITI DRAWING ATTACHED

Deputy General Manager(MM)

Central Purchase,

ITI Limited,Dooravaninagar

Bangalore-560016

Thanking You.

Yours Faithfully,

For I.T.I Limited

CHIEF MATERIAL MANAGER

SI NO	ITI CODE	DETAILED DESCRIPTION
1	ASCRNT-1	"M10 Nutsert (Blind Rivet nut)-Semi-Hex shank , Large Flange , open type , Grip range-1mm to 4mm ,Length-22mm , Steel-Zn plated."
2	ASCRVTBLB/1	"Semistructural Dome head Blind Bulb Rivet , Steel-Znplated-Steel-ZnPlated Size 4 X 10 Grip range 3 to 5 mm ( refer drawing)"
3	ASCRVTBLB/3	"Semistructural Dome head Blind Bulb Rivet , Steel-Znplated-Steel-ZnPlated Size 4.8 X 14 Grip range 6 to 8.5mm ( refer drawing)"



\* Purchased Item

Source of supply refer sh.2

SHEET:-1 OF 2		
ISSUE	APP	
01	DATE	MAR
	24/06/21	

PERFORMANCE DATA		TECHNICAL SPECIFICATIONS								
PULL OUT KN	PUSH OUT KN	Recommended torque	Collar thickness (t)	Across flat (A/F)	Body length (L)	Collar dia (D)	Body dia (d)	Grip range	Thread size	Detail
MIN 5.9KN	MIN 5.9KN	45 - 48 Nm	2 ± 0.2 mm	13 ± 0.2 mm	20 ± 2 mm	18 ± 1.8 mm	13 ± 0.2 mm	1.0 - 3.5mm	M10 x 1.5mm	1

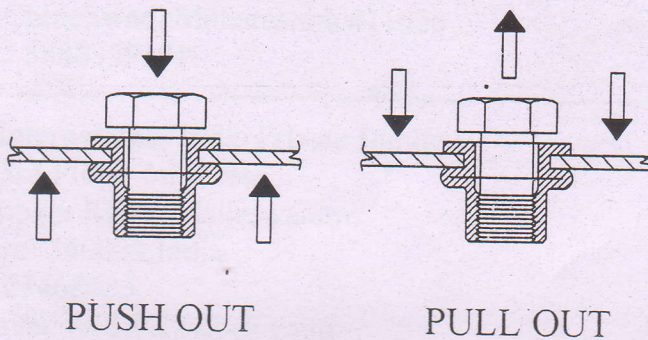
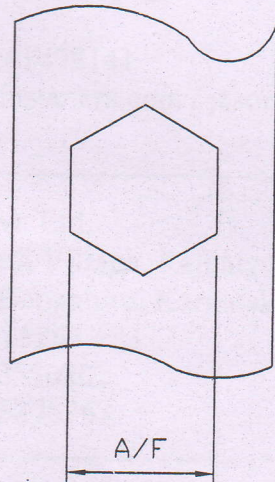
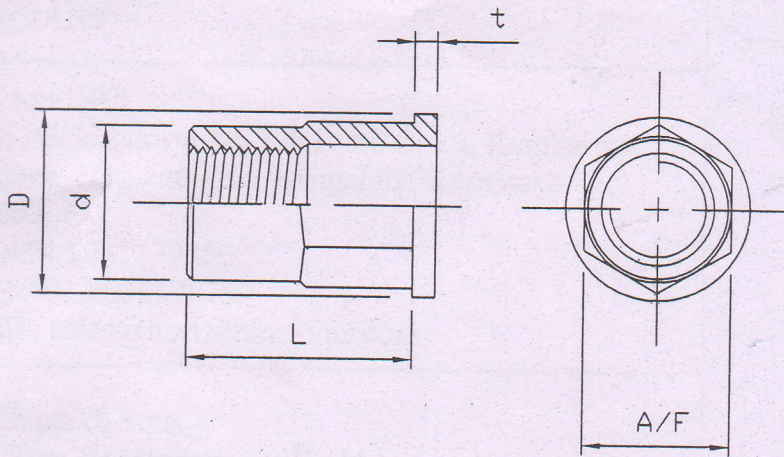

ALL DIMENSIONS ARE IN 'mm'

TOLERANCES TO RULING NO. 16

REF: ASCON 42U Rack.

W.O:

U.O:

Note:

1. Material - Steel, Zinc plated
2. Sample to be submitted along with catalogue, technical data sheet for approval during enquiry stage, before bulk procurement stage.

# NUTSERT (RIVET NUT) (Semi Hexagonal, Flange type)

DRN	R. D.		
TRD.			
CHKD	APPROVED		
ASCRNT		ITL LIMITED BANGALORE-16	A4



**\* Purchased Item**

Source of supply refer sh.2

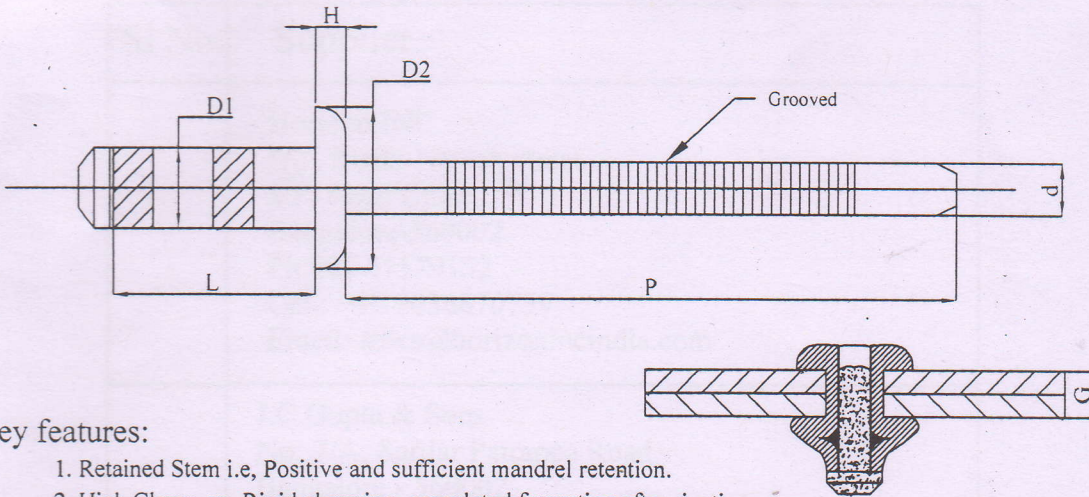

**Key features:**

1. Retained Stem i.e, Positive and sufficient mandrel retention.
2. High Clamp-up, Rigid clamping, completed formation after riveting.
3. Large blind side bearing area / foot print.
4. For use in heavy duty applications.
5. Riveting by using standard riveting gun.

**1. SPECIFICATIONS**

Detail	Rivet Dia (D1)	Length(L)	Grip Range(G)	Domed Head Dia(D2)	Head Height(H)	Mandrel Dia(d)	Mandrel length(P)	Drill Dia
1	4.0	10 ± 1	3.0 - 5.0	8 ± 1	1.5 ± 0.2	2.6 ± 0.2	30 ± 5	4.2 ± 0.1
2	4.8	12 ± 1	3.5 - 6.0	9.6 ± 1	1.5 ± 0.2	3.2 ± 0.2	30 ± 5	5.0 ± 0.1
3	4.8	14 ± 1	6.0 - 8.5	9.6 ± 1	1.5 ± 0.2	3.2 ± 0.2	30 ± 5	5.0 ± 0.1

**2. MECHANICAL PROPERTIES**

Property	Requirement(min)	
	@D1= 4.0 mm	@D1= 4.8mm
Tensile Strength	2.00 KN	3.00 KN
Shear strength	2.00 KN	3.00 KN

**3. MATERIAL USED**

	BODY	MANDREL
MATERIAL	STEEL	STEEL
FINISH	ZINC PLATED	ZINC PLATED

Make and part no. shall be as below,

MAKE	PART CODE FOR DET.1	PART CODE FOR DET.2	PART CODE FOR DET.3
AVDEL(STANLEY)	0BN01-00512 (AVIBULB)	0BN01-00614 (AVIBULB)	0BN01-00618 (AVIBULB)
AVLOCK	HBS44-14010GG (HYDRABULB)	HBS44-14811GG (HYDRABULB)	HBS44-14814GG (HYDRABULB)
GOEBEL	SBS-0512-GB (GO-BULB) (Semistructural Blind Rivet)	SBS-0614-GB (GO-BULB) (Semistructural Blind Rivet)	SBS-0618-GB (GO-BULB) (Semistructural Blind Rivet)
TITONAX RIVELIT	E MH TP ACAC 4012 (Riv-Elit) (High Strength steel Breakstem Rivet)	E MH TP ACAC 4814 (Riv-Elit) (High Strength steel Breakstem Rivet)	E MH TP ACAC 4817 (Riv-Elit) (High Strength steel Breakstem Rivet)
PATTA	HK-LOK, High Strength Blind Rivet, Steel/Steel Dome Head, size 4.0X10mm(L), Grip range 3.0-5.0mm	HK-LOK, High Strength Blind Rivet, Steel/Steel Dome Head, size 4.8X12mm(L), Grip range 3.5-6.0mm	HK-LOK, High Strength Blind Rivet, Steel/Steel Dome Head, size 4.8X14.5mm(L), Grip range 6.0-8.5mm

ALL DIMENSIONS ARE IN 'mm'

TOLERANCES TO RULING NO. 16

ASCON 42U Rack.

**Note:**

1. Vendor shall ensure offer, supply as per above Make & part nos.
2. Sample to be submitted along with catalogue, technical data sheet for approval during enquiry stage, before bulk procurement stage.
3. In case of order, NABL certificate to be provided for Tensile and Shear strength.

**SEMI STRUCTURAL BLIND RIVET  
BULB TYPE, DOME HEAD,  
STEEL ZINC PLATED/STEEL ZINC PLATED**

DRN	<i>R. Kumar</i>
TRD.	
CHKD	<i>ALLI</i>

APP.

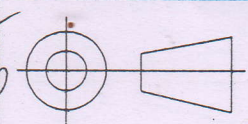

**ASCRVTBLB**

ITI LIMITED  
BANGALORE-16

A4



